



青島三安機械有限公司

SAN(QINGDAO)MACHINERY CO.,LTD.

Address: 2208 No. 33 lianyungang Road Qingdao, China

Tel: 86-532-55570881 Fax: 86-532-55570885

Email: info@sanmachinery.com

Website: www.sanmachinery.com

工厂地址: 青島膠州市廣州北路666號

電話: 0532-83233236 傳真: 0532-83243169

網址: www.sanjixie.com



1. 三安机械是谁?

三安机械是纸护角生产医生, 为您提供用心、专业的服务和省心、省力产品。
三安机械成立于2005年,是最好的纸护角生产服务者。

Who we are?

We,SAN (QINGDAO) MACHINERY CO., LTD. ,are the doctor for paper protector production to provide you professional services wholeheartedly and supply you trustworthy and high efficiency products.

We ,established in 2005 and become the best supplier for paper protector production.

2. 三安机械提供什么?

三安机械致力于纸护角生产项目的咨询、纸护角生产设备的研发、生产和技术支持。三安机械提供纸护角生产线、纸平板生产线、纸分切复卷机和纸护角后加工设备。

What we offer?

We are engaged in project consulting, machine supply and technical support for paper edge protector production.

We are offering paper edge protector production lines, paper slip sheet production line, paper splitter & rewinder and paper protector converting machines.

3. 三安机械特色是什么?

诚实、守信, 质量第一, 永远的质量第一。

产品通过CE认证和SGS质量体系认证。

产品远销智利、印度尼西亚、波兰、意大利、阿根廷、斯洛伐克、捷克、埃及、墨西哥、匈牙利、克罗地亚、科特迪瓦、肯尼亚、美国、越南、菲律宾、马其顿、哥伦比亚、土耳其、南非、韩国、阿拉伯、印度等世界各地。

What's our special?

Honest and trustworthy, quality first!

To guarantee machine production quality and service quality, we are managing our factory and producing machine as per CE certification and SGS system. We are professional for paper protector machine. We supplied machines to Chile, Indonesia, Poland, Italy, Argentina, Slovakia, Czech, Egypt, Mexico, Hungary, Croatia, COTE D'IVOIRE, Kenya, USA, Vietnam, Thailand, Philippine, Macedonia, Colombia, Turkey, South Africa, South Korea, UAE, India etc.

企业资质:

Certification:

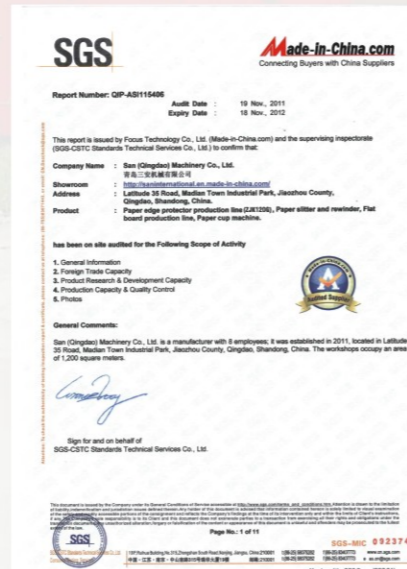

纸护角应用 Paper protector application

纸护角在运输包装中起到越来越重要的作用, 在传统的L型护角后, 又相继发展U型, 圆形以及平板等特殊形状的纸护角。纸护角是您避免运输、储藏过程中货物受损的最佳选择。

Paper protector is more and more popular in the packing industry. We developed U profile, rounded profile and Flat board after L profile protector. Paper protector boards are the right solution to prevent your products from damage during storage and transportation.

直角边缘保护 Edge protection

方形边缘保护 Corner protection

环形边缘保护 Protection frame for drums or round packing

纸箱内部支撑 Inner protector for paper boxes.

纸托盘边缘 Edge protection for Paper pallet.

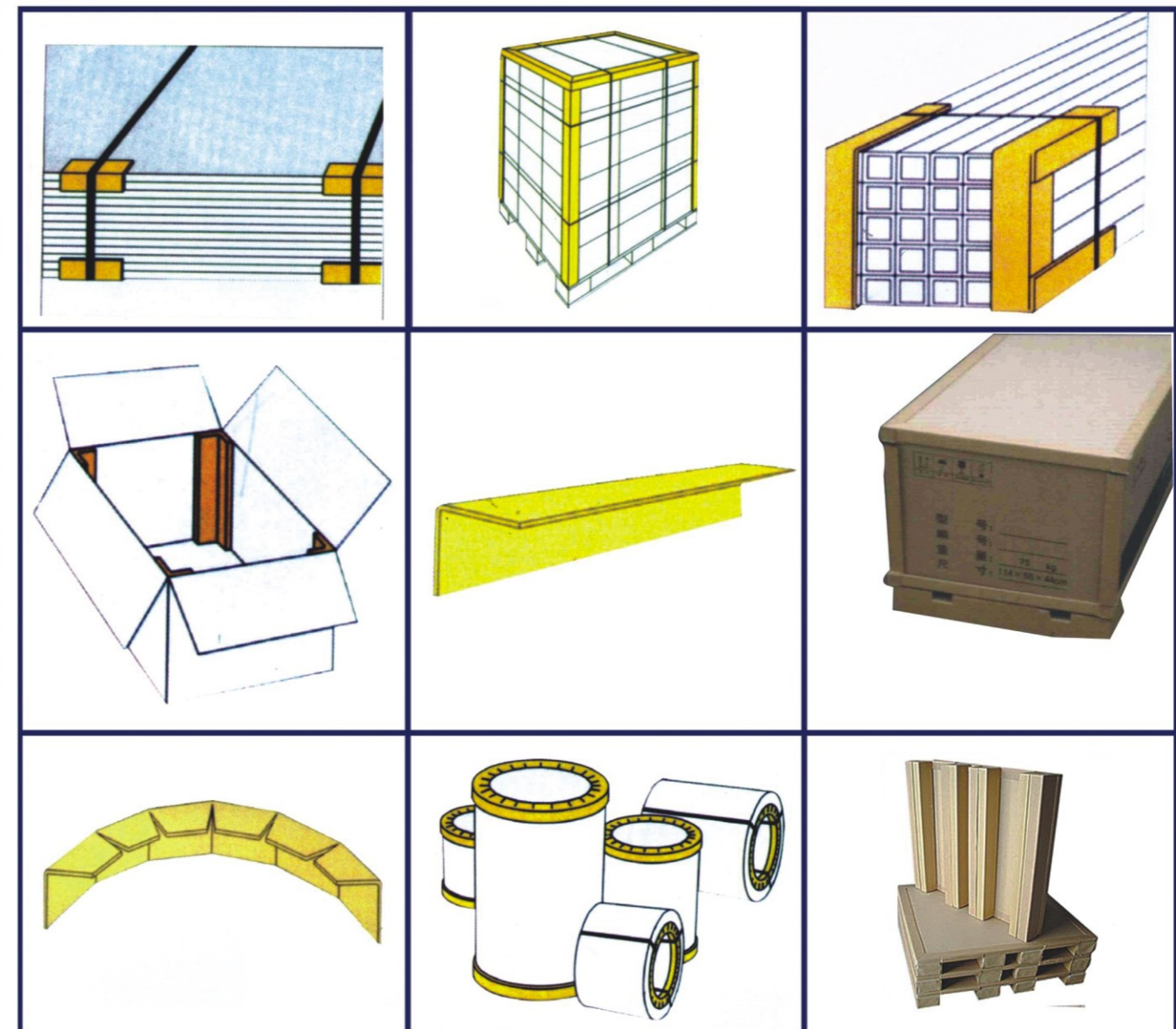

G系列纸护角生产线

最高生产速度可达到50m/min。SANPPL-120GL为基本型号，单用生产L型护角，可以更换模具等装置，生产U形和平板护角。

G series paper edge protector line SANPPL-120GL is for L profile paper edge protector production. Through changing tools, it can produce U profile protector and Flat board.

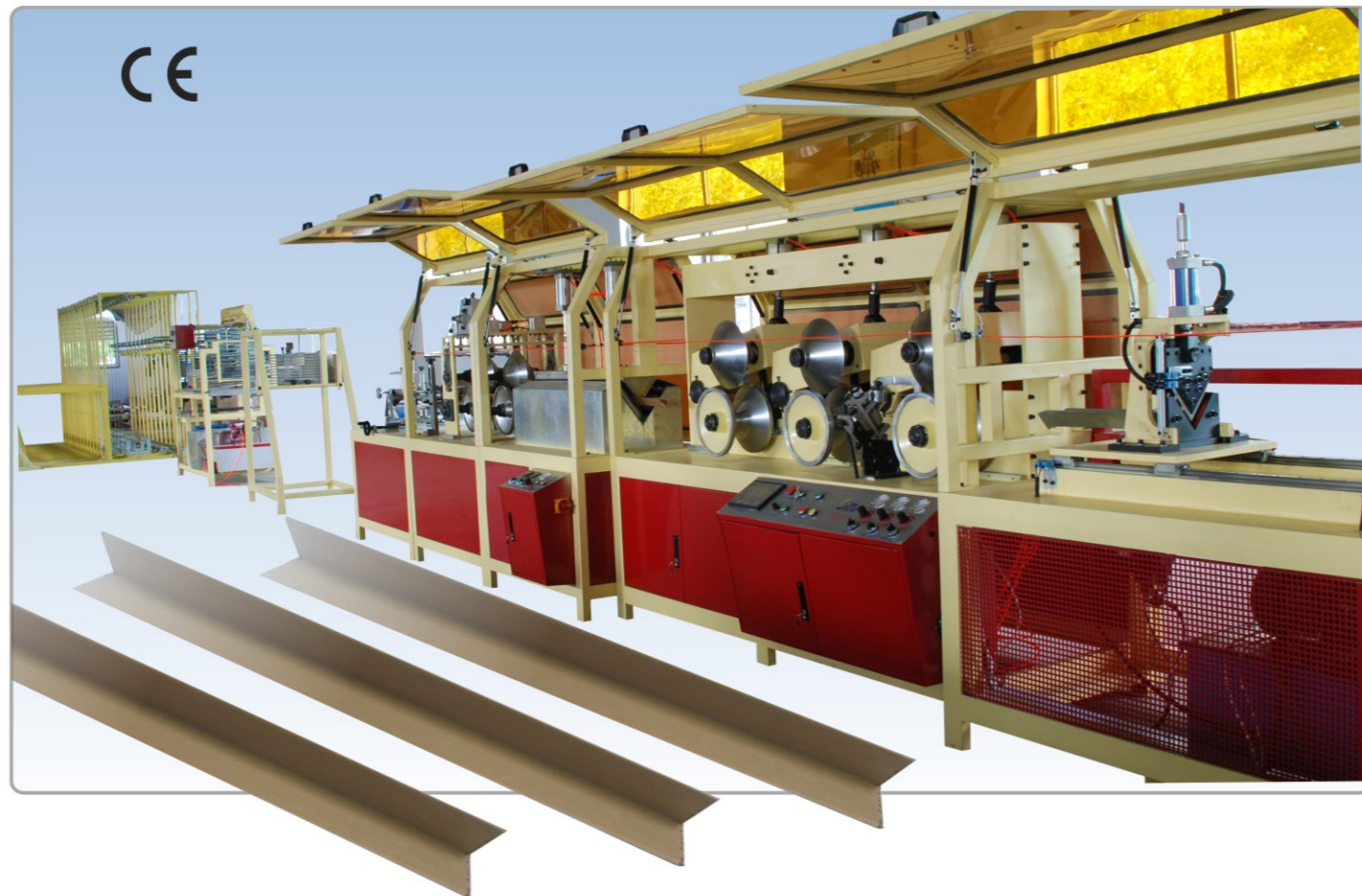

生产纸护角规格 Size of protector	25~100mm
最高生产速度 Max production speed	50m/min
纸张最多层数 Max. quantity of layer	13层含1层面纸 13 layer including 1 layer surface paper
面纸采用纸张要求 Applicable surface paper	175-250g牛皮纸 175-250g craft paper
纸芯采用纸张要求 Applicable inner paper	360g-600g 沙管纸 360g-600g Bobbin fiber paper.
外形尺寸 Overall dimension	24.5 × 1.8 × 1.9m 行车最高2.9m Highest point for hoist is 2.9m
总重量 Total weight	5.5T
总功率 Total power	31kW
压缩空气要求 Compressed air supply	0.6Mpa,0.2m3/min



G 型上纸架 (G paper stand)



G 型成型部 (G forming system)



G 型加热部 (G heating system)

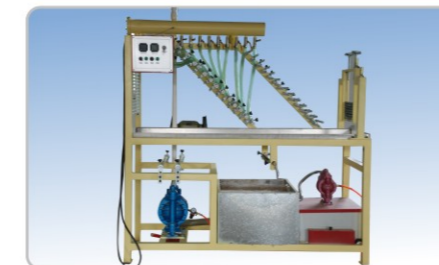

G 型上胶架 (G gluing system)

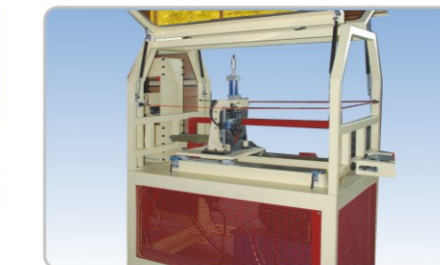

G 型裁切部 (G cutting system)



GL自动收料台
(GL automatic stacking system)

性能及特点:

- 采用积聚上纸架，有缓冲作用，方便换纸，无需停机。同时配有行车上纸，方便快捷。
- 自动温控上胶系统，低温条件下保证生产速度和产品质量。
- 生产线加热系统，保证高强度粘合效果。
- 成型轮采用箱式悬挂结构，模具更换方便。
- 触摸屏和伺服系统人机界面，操作更人性化，气缸调压更方便。
- 自动报警，故障提示，调整、维护方便。
- 液压裁切系统，最快频率90次/分钟。
- 自动收料装置，配有自动计数器，无需人工计数。
- 可以通过更换模具生产L型、U型和平板等不同类型的纸护角。

Main features:

- Suspended paper stand with buffering effect, replace the paper rolls with hoist, no need stop the machine.
- Automatic controller for glue temperature ensures the good quality even in winter.
- Heating system for production line, makes the protectors more strong.
- Molding wheels adopt box type suspended structure, easy to change mould.
- Touch screen and human-computer interface of servo system, the operation is more personalization, the operation for adjust air cylinder is more convenience.
- Automatic to alarm, malfunction, easy to adjust and maintenance.
- Hydraulic cutting system, maximum frequency is 90times/minutes.
- Automatic stacking system with counter.
- Through changing tools, it can produce U profile protector and Flat board.

D系列纸护角生产线

最高生产速度为30m/min。SANPPL-120DL为基本型号，生产L型护角，通过更换模具等装置可以生产U形和平板护角。SANPPL-120DLU、SANPPL-120DLF两用机和SANPPL-120DLUF三用机型无需更换模具，通过改变模具的位置即可生产两种和三种不同类型护角。

D series paper edge protector line

Max. speed is 30m/min. SANPPL-120DL is for L profile paper edge protector production. Through changing tools, it can produce U profile protector and Flat board. SANPPL-120DLU or SANPPL-120DLF double purpose machine and SANPPL-120DLUF triple purpose machine can produce two and three types protector without changing tools.

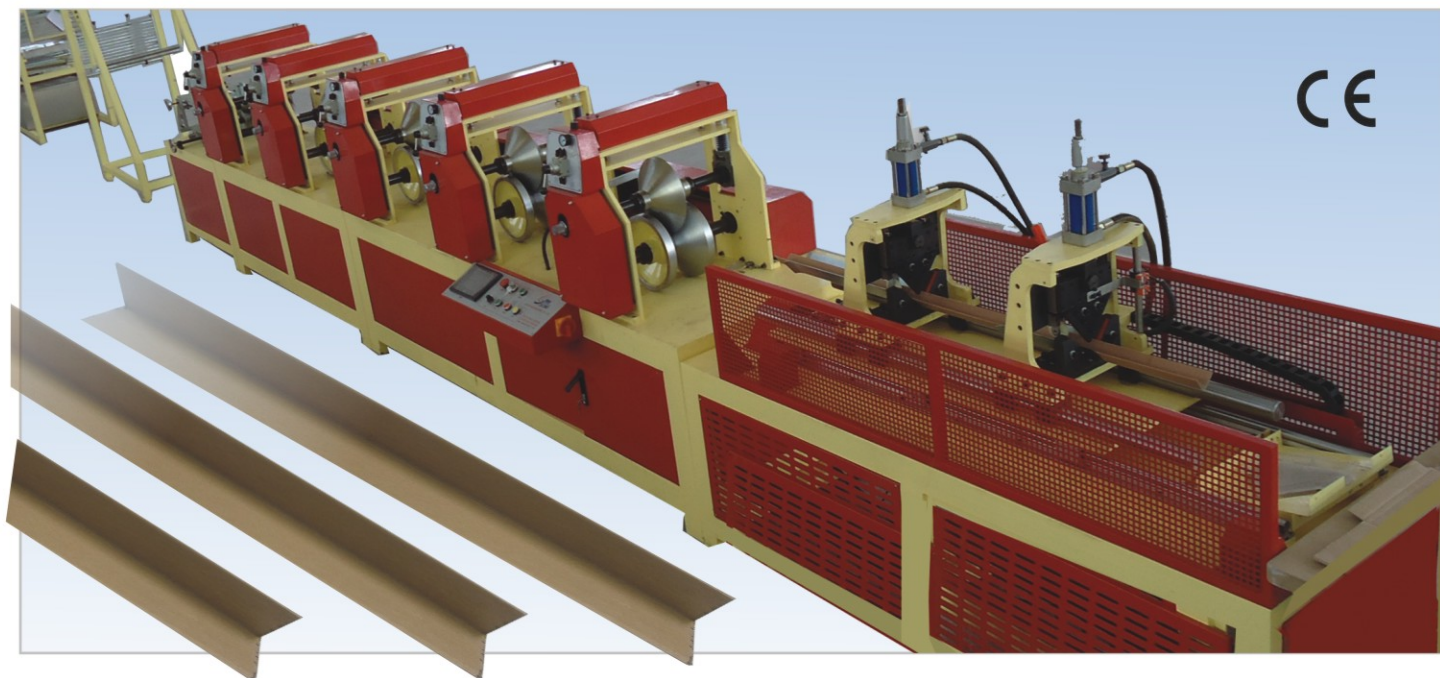

生产纸护角规格 Size of protector	25~100mm
最高生产速度 Max production speed	30m/min
纸张最多层数 Max. quantity of layer	13层含1层面纸 13 layer including 1 layer surface paper
面纸采用纸张要求 Applicable surface paper	175-250g牛皮纸 175-250g craft paper
纸芯采用纸张要求 Applicable inner paper	360g-600g 沙管纸 360g-600g Bobbin fiber paper.
外形尺寸 Overall dimension	24.5 × 1.8 × 1.9m 如增加行车, 最高2.9m Highest point for added hoist is 2.9m
总重量 Total weight	4.5T
总功率 Total power	9.5kW
压缩空气要求 Compressed air supply	0.6Mpa,0.2m3/min

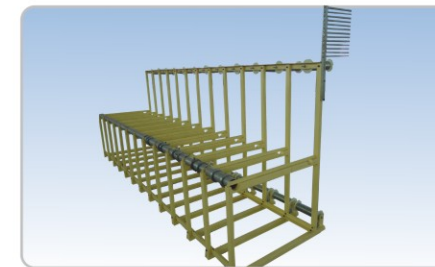

D 型上纸架 (D paper stands)

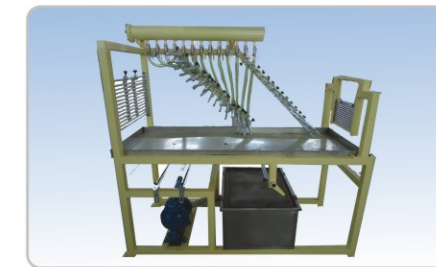

D 型上胶架 (D gluing system)



D 控制面板(D control panel)



D成型部 (D forming system)

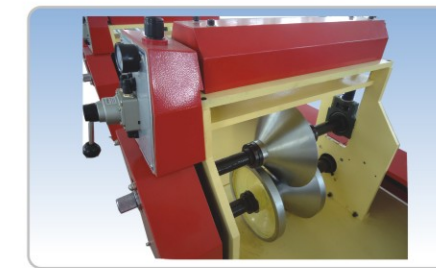

L 模具 (L profile tools)

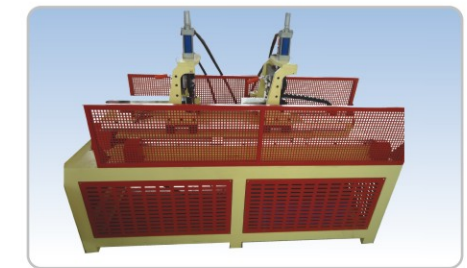

D 裁切系统(D cutting system)

性能及特点:

- 复合式上纸架，方便上纸。可增配行车。
- 双面上胶，自动定量上胶。
- 更换模具生产多种纸护角。
- 气动压力控制系统，模具更换方便。
- 触摸屏和伺服系统人机界面，操作更人性化。
- 自动报警，故障提示，调整、维护方便。
- 双组液压裁切系统，最快频率80次/分钟。
- 可以通过更换模具生产L型,U型和平板等不同类型的纸护角。

Main features:

- Composite paper stands,hoist can be added.
- Double surface gluing system. Quantify the glue automatically.
- Produce different profile protectors through changing moulds.
- Pneumatic press system, easy to change moulds.
- Touch screen and human-computer interface of servo system, the operation is more personalization, the operation for adjust air cylinder is more convenience.
- Automatic to alarm, malfunction, easy to adjust and maintenance.
- Hydraulic cutting system, Double heads. Maximum frequency is 80times/minutes.



SANPPL-1600纸平板生产线

该机型适用于生产运输用纸滑板，纸托盘等，最大加工宽度1600mm. 整机采用PLC控制，最高速度可达30m/min.

SANPPL-1600F Flat Cardboard Production Line

SANPPL-1600F line is the latest developed paper sheet production line with Max. width 1600mm. The system is controlled by PLC, Max. speed can be 30m/min.

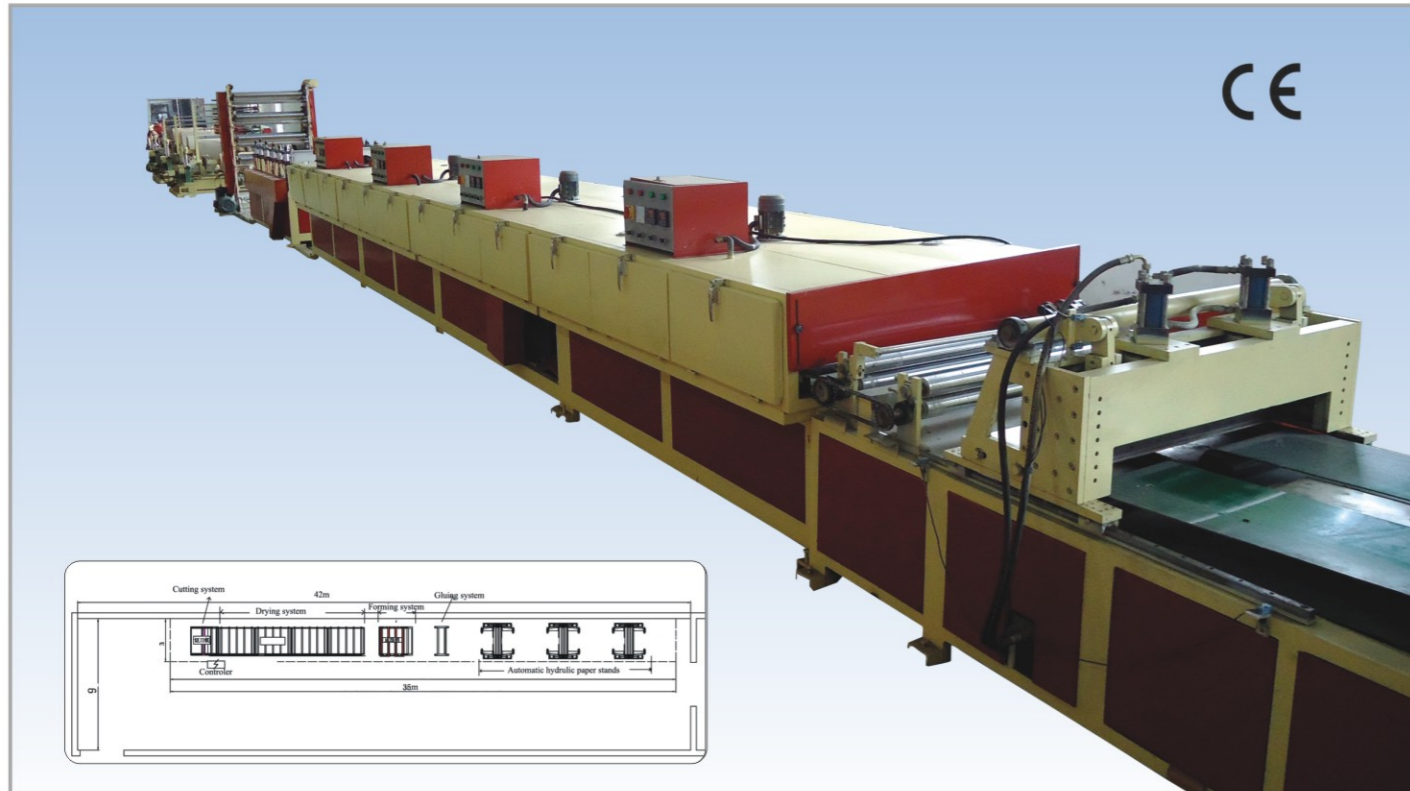

型号 Model	SANPPL-1600 F
最大宽度Max. board width size(mm)	1600
最小宽度Min. board width (mm)	50
厚度Thickness(mm)	≤5mm
纸芯纸Applicable paper	360-600g/m2 砂管纸fluting paper or kraft paper
面纸Surface Paper	170-220g/m2 牛皮纸craft paper
最大层数Max. quantity of Layer	6
最大速度Max. speed	30m/min
控制系统Control system	松下PLC, 伺服电机, PLC(Panasonic) and servo motor,
上纸架Paper stand:	自动液压无轴上纸架Automatic hydraulic paper stands without spindle.
上胶系统Gluing system:	辊涂式上胶Roller gluing system
压力系统Pressing system:	气压Pneumatic press
加热装置Heating system:	节能热风循环系统Can adjust temperature of the air.
切割方式Cut method:	自动液压裁切Automatic hydraulic cutting
纵切系统Longitudinal cutting:	4把纵向切刀，可调节宽度。4 knives, can adjust the width of the smaller belt.

SANJQ 自动精切机

SANJQ 自动精切机用于把长纸管切成短纸管。

SANJQ automatic tube recutter is used for cutting long master paper tube into required short length tubes.

此机器拥有以下特点 The machine owns below features :

松下PLC和变频器 Panasonic PLC and inverter.

松下伺服电机 Panasonic servo motor.

触摸屏 Touching panel.

THK高速螺杆和THK直线导轨 THK high speed screw and THK linear guide rail.



纸管内径 Tube inner diameter	30-250mm
纸管长度 Tube length	20-2000mm
纸管厚度 Tube thickness	1.2-20mm
切刀 Blade	2pcs
切割精度 Cutting tolerance	± 0.2mm
速度 Speed	50times/min
电源 Power	4KW/380V/50HZ/3 phases
重量 Weight	1300kg
外型尺寸 Dimension	4000mmX1500mmX1500mm

纸张分切复卷机 Paper splitter and rewinder

用于将大纸卷分切成小纸卷。This machine is to slit jumbo paper roll into small rolls.

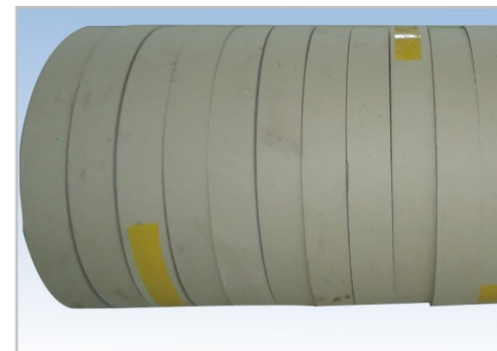
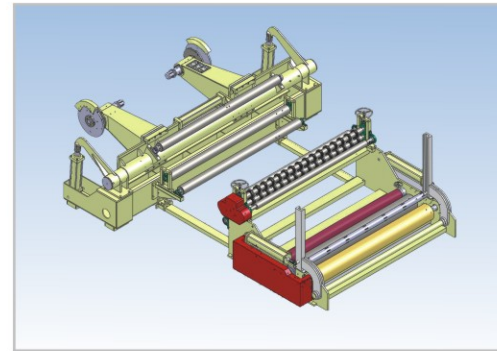
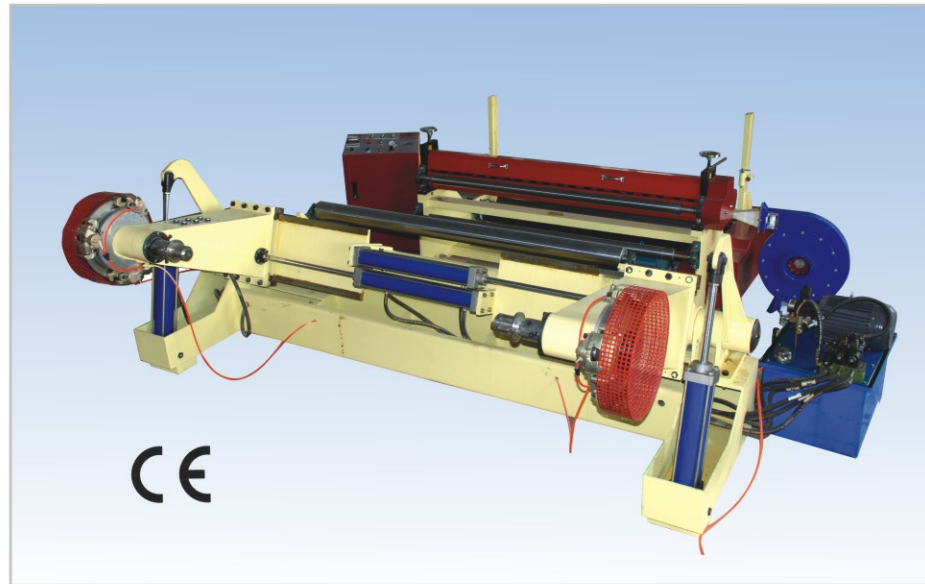

特点

- 液压无轴上纸架，上纸方便，快捷
- 电控液压纠偏，精度高
- 悬浮式张力系统，保持张力恒定
- 加重型分切组件，分切质量更好
- 复卷不粘连，保证纸卷间距1-2mm
- 单组式地辊复卷，重心低，卸纸更方便

Features:

- Hydraulic paper stand, easy for loading paper roll.
- Automatic centering system, small tolerance.
- Suspended tension system. Keep the machine steady performance.
- Heavy body with steady performance.
- Separate the rolls with Min.1-2mm distance
- Single bottom roller rewinding system. Easy for unloading.

型号 Model	SANSR-1600
最大加工宽度 Max. working width	1600mm
最小加工宽度 Min. working width	600mm
最大加工直径 Max. diameter of raw material	1300mm
加工速度 Working speed	0-140m/min
切刀数量 Quantity of blades	16
电源 Power supply	10.5kW, 380V, 50HZ
上纸架 Paper stand	液压无轴上纸架 Hydraulic paper stand without spindle
重量 weight	3500KG

柔版滚切机 paper protector flexo die cutting machine

用于纸护角V型开口，做外圆和内圆边缘纸护角。

Make V cut for outer round protector and line cut for inner round protector.

型号 Model: SANGD-120L

加工尺寸: Protector size: 25-100mm

纸护角厚度: Protector thickness: 2mm-3.5mm

生产速度 Production speed: 0-70m/min

开口数量 Cut quantity: 1-24/meter

电源要求 Power supply: 2.2 KW, 380V, 50HZ

外形尺寸 Dimension: 1300*1000*1600mm

重量 Weight: 550KG



纸护角冲床 paper protector puncher

用于制作圆形纸护角，直角护角以及其他形状的纸护角。

Punch protector to make round, square and any shape protector.

型号 Model: SANCQ

压力 Force: 100KN

外形尺寸 Dimension: 895*713*1653mm

重量 Weight: 576kg

电源 Power: 1.1kW

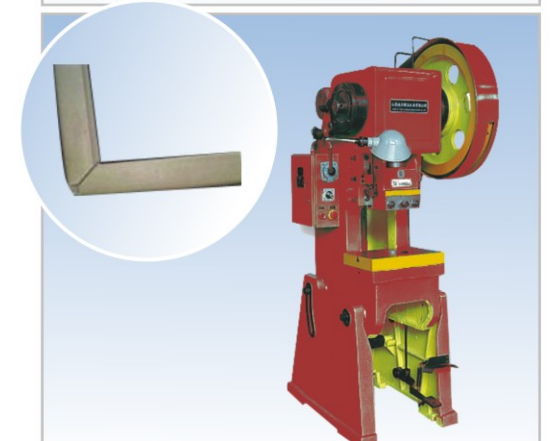

纸护角切段机 Paper protector recutter

用于将纸护角切成更小的尺寸。

Re-cut paper edge protector into small pieces.

型号 Model: SANQD

加工尺寸 Protector size: 25-100mm

加工厚度 Protector thickness: 25mm

加工速度 Production speed: 40cuts/min

外形尺寸 Dimension: 900*430*1500mm

重量 Weight: 80KG



单色印刷机 Single color on-line printer

用于纸护角单色印刷。

Print single color on surface paper of paper edge protector.

型号 Model: SANOLP

护角尺寸 Protector size: 25-100mm

颜色数量 Color quantity: 1

外形尺寸 Dimension: 1300*750*1050mm

重量 Weight: 180KG

印刷辊直径: Diameter of printing roller: 178mm

